



www.watchguardalarms.com.au

MODEL: DVR4ENTPACK3

# ***Professional Surveillance Pack***

***Digital Video Recorder with 4 Security Cameras***

## ***'QUICK INSTALLATION GUIDE'***



### ***DVR***

- Advanced H.264 Video Compression Technology
- Multiplex Operation
- Long Recording Duration
- Intelligent Video Motion Detection Recording
- Remote Network Surveillance & Backup Functions
- Easy to operate like a VCR
- System Auto recovery after power loss (blackout)

### ***4 x 10 IR Day/Night Cameras***

- High Quality CCD Image sensor
- 14 x IR LEDs
- 480 TVL Resolution

**Package Contents** (Before commencing installation, please ensure you have all the parts listed below.)

	<p><b>1 x 4 CH Digital Video Recorder with 250GB Hard Disk Drive &amp; PC Software for Remote View</b></p> <ul style="list-style-type: none"><li>● Advanced H.264 Video Compression Technology for High Quality Images and Small File Sizes</li><li>● Easy to Operate - Just Like a VCR</li><li>● Can be Connected to a PC Network for Remote Viewing &amp; Backup (Software on CD)</li><li>● For More Details, Please See Bottom of this Box</li></ul>
	<p><b>4 x Day/Night Weatherproof Colour Cameras with Infrared LEDs - 10m Range</b></p> <ul style="list-style-type: none"><li>● High Quality CCD Image Sensor (Not Inferior CMOS Type) for Superior Picture Quality</li><li>● IR LEDs for Viewing in Total Darkness up to 10m (B&amp;W Mode)</li><li>● 480 TVL Resolution</li><li>● Compact Size Ideal for Use Indoors or Out</li></ul>
	<p><b>4 x Camera Connection Cables</b></p> <ul style="list-style-type: none"><li>● Combined DC Power and Video Leads</li><li>● Pre-terminated - Allowing Simple Plug-in Connection – No Tools Required</li><li>● 2 x 10m, 1 x 20m, 1 x 30m Leads Supplied</li></ul>
	<p><b>1 x Power Split Cable</b></p> <ul style="list-style-type: none"><li>● Allows You to Connect All 4 Cameras to 1 Power Supply</li></ul> <p><b>1 x Monitor Connection Cable</b></p> <ul style="list-style-type: none"><li>● Connect the BNC Monitor Output from the DVR to the RCA Video Input on Your TV / VCR</li></ul> <p><b>1 x Network Cable (Optional Use)</b></p> <ul style="list-style-type: none"><li>● Allows You to Connect the LAN Port on the DVR to Your PC or Network to Facilitate Remote Viewing or Backup Functions</li></ul>
	<p><b>2 x Switch Mode Low Voltage Power Supplies</b></p> <ul style="list-style-type: none"><li>● 1 x 3Amp 12VDC Supply for Use with the Power Split Cable to Power All Cameras</li><li>● 1 x 2Amp 19VDC Power Supply for Use with the DVR</li><li>● Advanced Switch Mode Technology</li></ul>

\* Note: If you wish to connect directly from the DVR to a PC you require a crossover cable (Not Included)

## Installation

Before installing this unit, please read through the following points:

- Do not place cords from the AC adapter where they can be pinched or stepped on.
- Do not place heavy objects on cords, or cover cords with rugs or carpet.
- Never immerse any component in water, and do not spray cleaners or solvents on the unit. Unplug units before cleaning. When cleaning, use a damp, lint-free cloth only.
- Do not expose the DVR or Camera's to excessive heat, cold, or moisture
- Leave at least a 2" space between the DVR and other objects to allow air circulation around the unit.
- Service should be handled by qualified technicians.

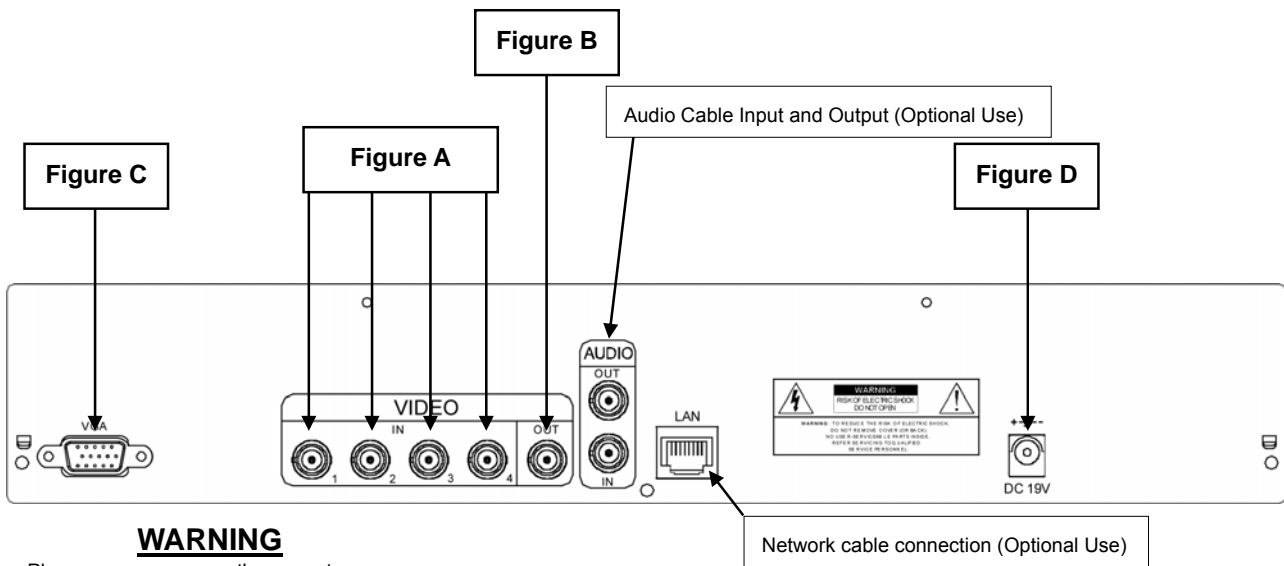

### **WARNING**

Please ensure you use the correct power supply for each component.

**DO NOT** plug the 19V DVR Power supply into the cameras as this will damage them.

## Connection Guide

1. Locate the 4 Cameras as required and connect the supplied combination DC Power and Video leads. (Yellow to Yellow / Red to Red)
2. Connect the 4 x corresponding camera Video leads (Yellow) into the camera inputs at the rear of the DVR (**Figure A**). Be sure to take note of the Camera input 1 – 4, as this will determine the camera channels.
3. Connect the 4 x camera Power leads (RED) into the Power Splitter Cable
4. If you are using a TV/Monitor with Composite Video Input, follow Step 4.1.  
If you are using a TV/Monitor with VGA input, follow Step 4.2
  - Connect the Monitor Connection Cable into the Composite Monitor output on the rear of the DVR (**Figure B**). Connect the Monitor Connection Cable into the RCA Video input on your TV/Monitor (TV/Monitor Not Supplied)
- 4.2 **NOTE: VGA Cable is not included.** Connect the VGA cable to the VGA output on the rear of the DVR (**Figure C**). Connect the other end of the VGA cable into the TV/Monitor VGA input.
5. Connect the 2Amp 19VDC Power adaptor to the DVR (**Figure D**).
6. Connect the 12VDC Power adaptor to the Power Split Cable.
7. Plug both Power adaptors into a Power-Point and switch the power-point ON
8. The Power LED at the front of the DVR should now be illuminated red and the unit will make a loud beep sound.

## Quick Start up Guide

- Make sure your TV/Monitor is ON and set to the appropriate AV channel if required
- Press the Power button located on the front panel of the DVR, the LED will illuminate Green. It takes approximately 10 to 15 seconds to boot the system.
- The images from all 4 cameras should now be displayed on your TV/Monitor
- **BEFORE BEGINNING TO RECORD YOU MUST SET the DATE and TIME on your DVR.**

## Setting the Date and Time

- Press "MENU" button to enter the (OSD) On Screen Display menu list.

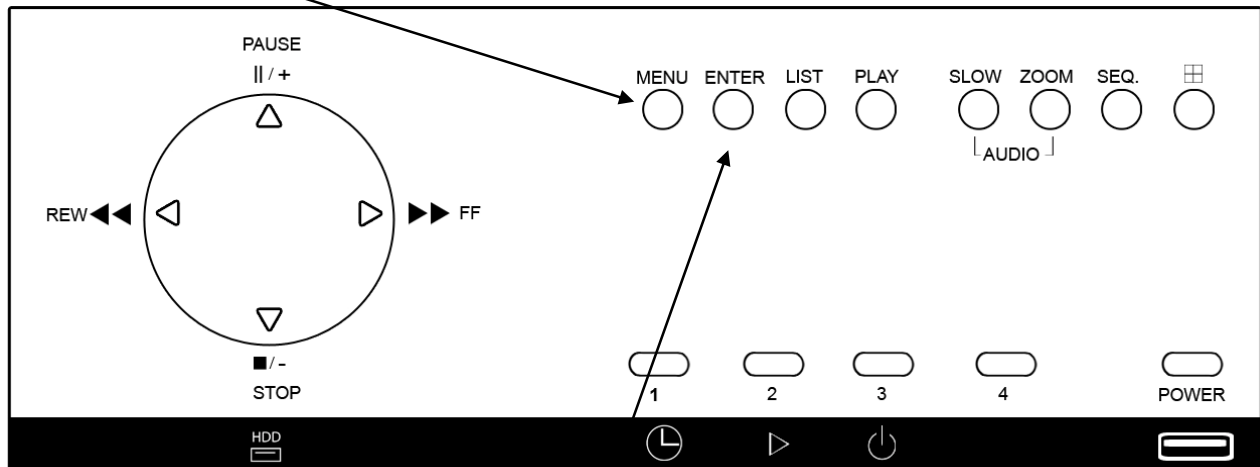

**The default admin password is 0000.**

Enter the default password by pressing "ENTER" 4 times.

*(Users can alter the password later. Please refer to the Advanced set up guide CD)*

- Use the following buttons to move the cursor for menu settings:  
"UP=▲,DOWN=▼,LEFT=◀,RIGHT=▶"

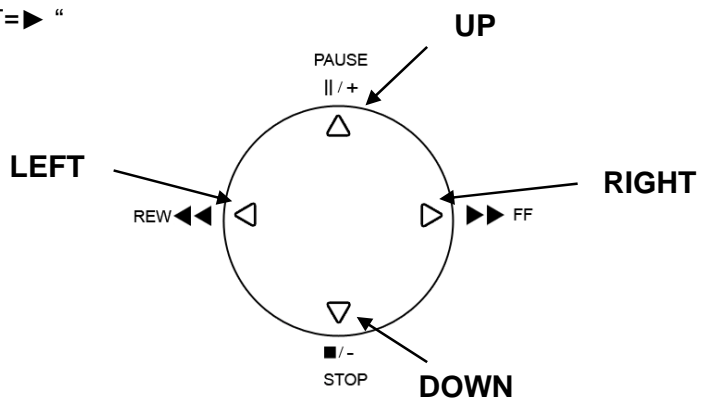
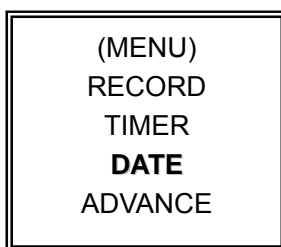

- Move the cursor to "DATE" and press "ENTER". The screen will show the following options:

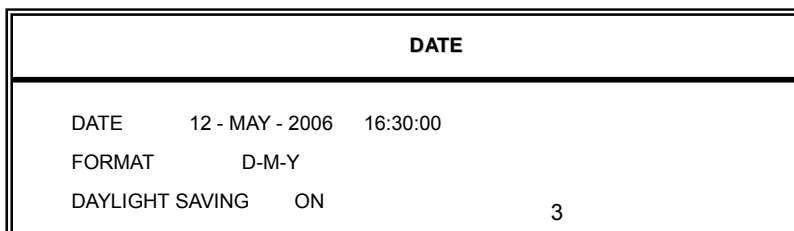

## Setting the Date and Time Cont.....

- Use the following buttons to set the correct Date and Time (DAY / MONTH / YEAR / HOUR / MIN / SEC)  
“▲▼◀▶” to move the cursor.  
“+”, “-” to choose the numbers / selections.  
“ENTER” to go to the submenu / to confirm the selection  
“MENU” to go to the menu OSD / to confirm the change / to exit the menu OSD

**IMPORTANT NOTE:** Please DO NOT change the date or time on your DVR after the recording function is activated. The recorded data will be disordered and you will not be able to find the recorded file to backup by time search.

**NOTE:** If users change the date or time accidentally when the recording function is activated, it's recommended to clear all HDD data, and start recording again.

## Daylight Saving

- Specify whether to use daylight saving time and time period. (START / END)
- Daylight saving time can be adjusted manually.
- Enter the daylight saving menu mode to set the start time and the end time, and adjust hours of the daylight saving.

DAYLIGHT SAVING		
START	4TH-SUN-OCT	01:00:00
END	4TH-SUN-MAR	01:00:00
ADJUST	01	:00

**NOTE:** The illustrated setting means: During the daylight saving time period (start from the 4th Sunday of October, end on the 4th Sunday of March), the DVR system time will add one hour.

## To Begin Recording

Once you have successfully set the Date and Time, exit the OSD Menu by pressing the “MENU” button until you return to normal viewing.

By default, the DVR will begin recording when it is properly connected to the cameras and has an installed HDD. If it is recording, the recording icon “” will be displayed on screen.



### To Stop Recording

In the event you wish to stop recording press the “ MENU “ button located at the front of the DVR.

- Move the cursor to “RECORD” and press, ”ENTER”.

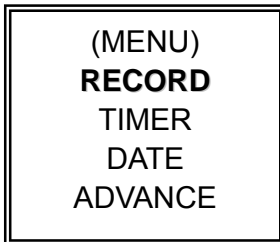

- The screen will show the following

RECORD	
MANUAL RECORD ENABLE	YES
EVENT RECORD ENABLE	NO
TIMER RECORD ENABLE	NO
OVERWRITE	YES
RECORD IMG SIZE	CIF
RECORD QUALITY	BEST
MANUAL RECORD IPS	012
EVENT RECORD IPS	012
TIMER RECORD IPS	012
TOTAL IPS SHARE	FIX

- Select “MANUAL RECORD ENABLE” and press “ENTER”
- The screen will now show the following

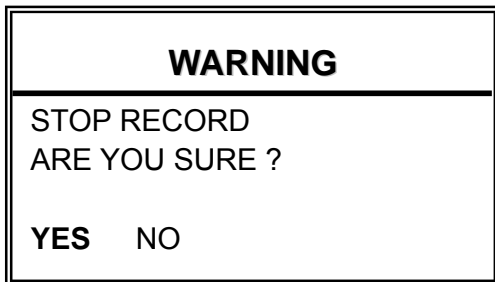

- Move the cursor to “YES” and press “ENTER”
- The DVR will now stop recording until the REC button is pressed again

## Recording Options:

### Recording Times

- This DVR is factory set to record “CIF Best Quality” at 3 frames per second, per camera, at a resolution of 352 x 288 pixels. This will provide approximately 8 weeks of recording time on this setting. Using Video Motion Detection or reducing image quality can achieve much longer record times if required.
- This unit can be set up to record up to a maximum of 6.25 frames per second per camera in “Frame Mode, 720 x 576 pixels, High Resolution” (MJPEG Compression) or 25 frames per second per camera in “CIF Mode (Real Time),(MPEG4 Compression) 352 x 288 pixels”

(To alter the recording method please refer to the Advanced set up guide CD)

## Recording Modes

The DVR offers three recording modes, **MANUAL RECORD**, **EVENT RECORD** and **TIMER RECORD**.



**\*\* This unit is set to “Manual Record” by the factory.**

( Please refer to the Advanced set up guide CD for details on how to change the recording mode)

### MANUAL RECORDING (continuous recording) :

Recording is initiated by manually pressing the “REC” button, indicated by the sign “” on the screen.

### EVENT RECORDING (triggered by motion and external alarm) :

When this function is activated, the recording is triggered by motion or external alarms, indicated by the sign “” (motion) or “” (external alarm) on the screen.

### TIMER RECORDING (scheduled time) :

Recording is scheduled by Timer, indicated by the sign “**TIMER RECORD**”.

**IMPORTANT NOTE** : If power is switched off accidentally or in the case of a black out, recorded video files will still be still stored in the HDD. The DVR will return to the original recording status after power is turned on again.

## Typical Viewing Screen

The image below shows a typical screen shot from an installation

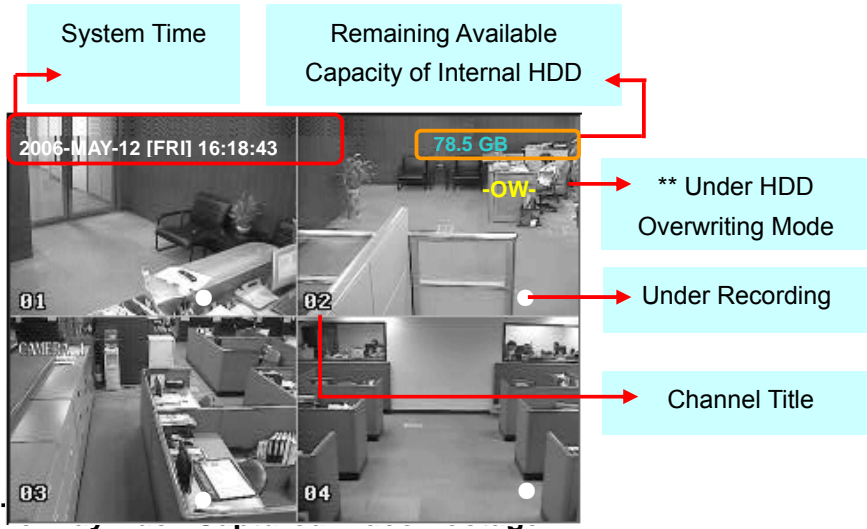

### \*\* Overwriting View

When the HDD is full under “-OW-” recording mode, the previous recorded data may be overwritten without further warning notice. Your DVR will clear 8GB from the oldest data for overwriting.

***Unit is pre-set by factory with Overwriting View Switched to on.***

Press “PLAY” button and the DVR will display the last recorded video.

### FAST FORWARD (F.F. ) & FAST REWIND (REW):

You can increase the speed for fast forward and rewind on the DVR in the playback mode,

- Press “▶▶” once to get 4X speed forward and press twice to get 8X speed, etc., and the maximum speed is 32X.
- Press “◀◀” once to get 4X speed rewind and press twice to get 8X speed, etc., and the maximum speed is 32X.

### SLOW PLAYBACK:

- Press “SLOW” button to get 1/2X speed playback.

### PAUSE / IMAGE JOG:

- Press “||” button to pause the current image displayed on the screen.  
In the Pause mode
- Press “▶▶” once to get one frame forward
- Press “◀◀” once to get one frame rewind

### CHANNEL SHIFT:

**Display mode:**

- Press MODE “” button to 4 channels display.

**Full Screen Switch:**

- Press “1” “2” “3” “4” buttons to show the full screen channels.

### STOP:

- Pressing “” button under all circumstances will return DVR to live monitoring mode

The image below shows a typical Play-Back screen shot from an installation



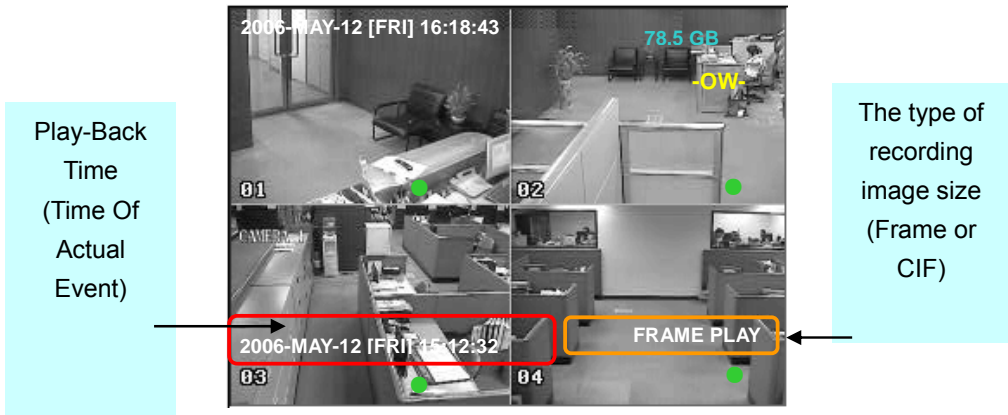

### Searching for data using Date and Time

You can also use the search function of the DVR to look back through stored data via date and time

- Press “LIST” button on the front panel of the DVR to enter the search mode.

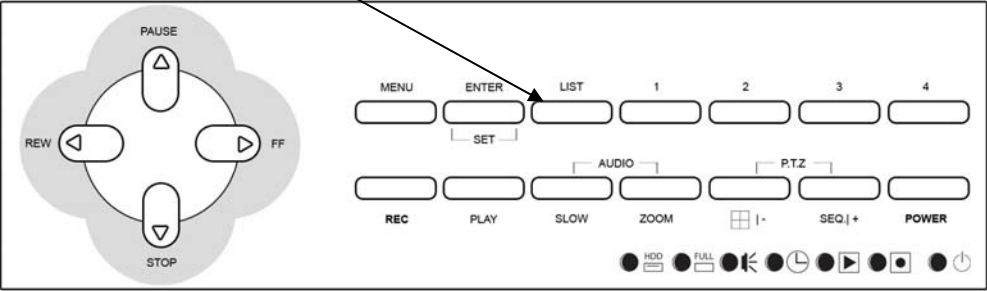

- Then the screen will show the following options.



- Select **"TIME SEARCH"** from the menu,
- Enter the Date and Time (DAY / MONTH / YEAR / HOUR / MIN / SEC) of the event you wish to view using the following buttons:

"▲▼◀▶" to move the cursor.

"+", "-" to choose the numbers / selections.

"ENTER" to go to the submenu / to confirm the selection

"MENU" to go to the menu OSD / to confirm the change / to exit the menu OSD

- Once you have entered the Date and Time move the cursor to the SELECT button and press "ENTER"
- The DVR will then start playing back recorded data from the selected period, use the FAST FORWARD / REWIND / PAUSE / SLOW PLAYBACK and CHANNEL SHIFT buttons on the unit to navigate through the footage as required
- To finish viewing the playback, press the stop "■" button to return to the live display

## Operation

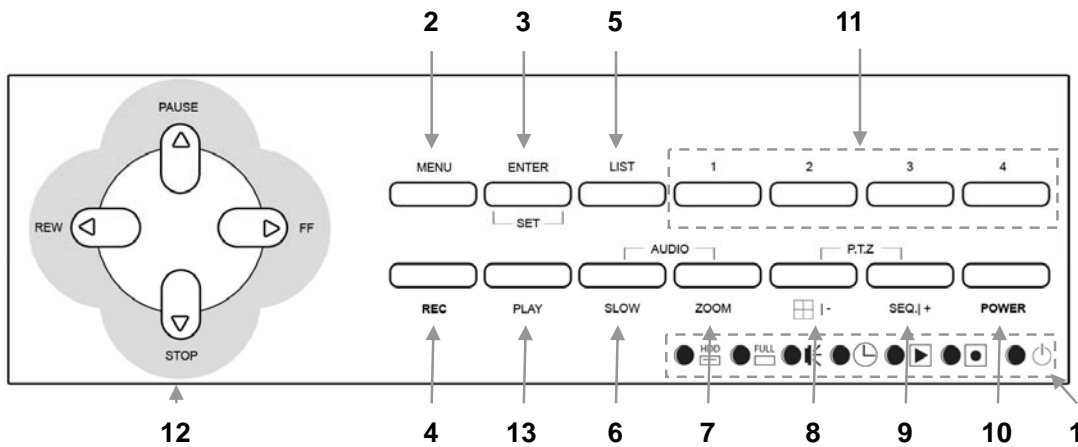

1	"LED LIGHTS"	<b>HDD:</b> HDD is reading or recording <b>HDD Full:</b> HDD is full. <b>ALARM:</b> Once the alarm is triggered <b>TIMER:</b> When timer recording is turned on <b>PLAY:</b> Under playing status <b>REC:</b> Under recording status
2	"MENU"	Press "MENU" button to enter the main menu.
3	"ENTER" / "SET"	Press "ENTER" button to confirm the setting. Press "SET" to change the position of the channel display. Press "▲▼◀▶" to select the channel which you would like to change. Press "+" or "-" to select the channel which You would like to show.
4	"REC"	Press "REC" button to activate the manual recording.
5	"LIST"	Press "LIST" button to enter the search menu.
6	"SLOW"	Under the playback mode, press "SLOW" button to show slow playback.
7	"ZOOM"	Press "ZOOM" button to enlarge the picture of selected channel (under the live mode).
8	" 4-channel icon " / " - "	Press " 4-channel icon " button to show the 4 channel display mode. Press " - " button to change the setting in the menu
9	"SEQ" / " + "	Press "SEQ" button to activate the call monitor function and press "SEQ" button again to escape the call monitor mode. Press "+" button to change the setting in the menu.
10	" Power " or "Power"	Press this button to turn (On / Off) the DVR. (Under the recording mode, please stop recording before turning off the DVR).
11	"CH1" "CH2" "CH3" "CH4"	Press "1" "2" "3" "4" buttons to select the channel to display
12	UP / PAUSE DOWN / STOP LEFT / REWIND RIGHT / FAST FORWARD	Press "▲▼◀▶" to move the cursor up / down / left / right. Under the playback mode, press " II " button to pause playback. Under the playback mode, press " ■ " button to stop playback. Under the playback mode, press " ▶▶ " button to fast forward. Under the playback mode, press " ◀◀ " button to fast rewind.
13	" PLAY "	Press " PLAY " to playback the recorded data
OPT	SLOW & ZOOM	Press these two buttons to select live or playback sounds of the audio channels.
OPT	4-channel icon & SEQ	Press these two buttons at the same time to enter / exit the PTZ control mode.

## TROUBLE SHOOTING

Please refer to the FAQ table below for easy troubleshooting. The table below describes some typical problems and also their solutions. Please check here and further FAQ on the included user manual CD before calling your DVR dealer.

PROBLEM	SOLUTION
No power	Check power cord connection. Confirm that there is power from the outlet.
Not working when pressing any button	Press any key and then enter the password to exit "Key Lock" mode.
Timer record is not working	Check if the "TIMER RECORD ENABLE" is set to "YES".
No live video	Check the camera's video cable and connections. Check the monitor's video cable and connections. Confirm the camera is power supplied. Check the setting of the camera lens.
No recorded video	Check if the HDD is installed and connected properly.
DVR keeps rebooting	Make sure the power connector and HDD are connected closely, or change another suitable HDD.
HDD detection failed	Change another HDD for testing. Change another HDD cable for testing. Make sure HDD "Master", "Slave" mode is correctly set.
Can't detect your USB flash drive	Change another USB flash drive to test.
Can't view the DVR images over the network with IE web browser	Update the JAVA program Update the firmware of the software AP
Can't play the recorded data on my DVR	There must be at least 8192 images of recorded data for playback to work properly. If not, your DVR will stop the playback. For example, if the IPS is set to 30, the recording time should be at least 273 seconds (8192 images / 30 IPS) for the playback to work properly.

***This guide is intended as a Quick Set Up and Basic use manual only, please refer to the user manual on the included CD for all other details.***

## Limited Warranty

Cornick Pty Ltd (Seller) warrants its products to be in conformance with its own plans and specifications and to be free from defects in materials and workmanship under normal use and service for twelve months from the date of original purchase. Sellers obligation shall be limited to repairing or replacing, at its option, free of charge for materials or labor, any part which is proved not in compliance with Sellers specifications or proves defective in materials or workmanship under normal use and service. Seller shall have no obligation under this Limited Warranty or otherwise if the product is altered or improperly repaired or serviced by anyone other than Seller.

**For Warranty Service:** Return transportation prepaid with a copy of your purchase receipt and contact details to:

**RhinoCo Technology, 9 Hannabus Place, McGraths Hill, NSW 2756 Australia.**

Seller has no obligation to attend the buyer's location to retrieve the goods or make repairs onsite.

- There are no warranties, expressed or implied, of merchant ability, or fitness for a particular purpose or otherwise, which extend beyond the description on the face hereof. In no case shall seller be liable to anyone for any consequential or incidental damages for breach of this or any other warranty, express or implied, or upon any other basis of liability whatsoever, even the loss or damage is caused by its own negligence or fault.
- Seller does not represent that the products it sells may not be compromised or circumvented; that the products will prevent any personal injury or property loss by burglary, robbery, fire or otherwise; or that the products will in all cases provide adequate warning or protection. Customer understands that a properly installed and maintained alarm system or video surveillance system may only reduce the risk of a burglary, robbery, or fire without warning, but it is not insurance or a guarantee that such will not occur or that there will be no personal injury or property loss as a result.
- Consequently, seller shall have no liability for any personal injury; property damage or other loss based on a claim the product failed to give any warning. However, if seller is held liable, whether directly or indirectly, for any loss or damage arising under this limited warranty or otherwise, regard less of cause or origin, seller's maximum liability shall not in any case exceed the purchase price of the product, which shall be the complete and exclusive remedy against seller.
- This warranty replaces any previous warranties and is the only warranty made by the Seller on this product. No increase or alteration, written or verbal, of the obligations of this Limited Warranty is authorised.

Please refer to the website ([www.watchguardalarms.com.au](http://www.watchguardalarms.com.au)) for a full list of trading terms.



**HELPDESK:** Phone 02 4577 4708

9am – 5pm Mon- Fri



PLEASE CUT OUT & RETURN THIS INFORMATION  
WITHIN 14 DAYS OF PURCHASE TO:

**RhinoCo Technology**  
9 Hannabus Place  
McGraths Hill NSW 2756 Australia

**Model:DVR4ENTPACK3**  
**Professional Surveillance Pack Warranty Card**

Name			
Address			
Suburb	State	Postcode	
Email			
Date of Purchase	Invoice Number		
Daytime Phone			
Where did you purchase your DVR4ENTPACK2?			
Store Location			

This information will only be used by the manufacturer and will not be sold to any third parties.

Dear Customer,

We appreciate your confidence in our product, and you can be certain that we will do everything possible to ensure that you are happy with your decision and that you have years of satisfaction from your DVR4ENTPACK2.

We take extreme care in the research, design and development of our products to ensure they meet your needs. Additionally, we keep in close contact with our dealers Australia wide, and should any problem occur, we will work closely with your local dealer to see that it is resolved quickly.

As a leading designer and manufacturer, we are continually endeavouring to exceed the expectations of our customers. Furthermore, we appreciate your input regarding potential design improvements, issues regarding our service and support, and any other ideas you may have which could help us to serve you better.

Please make any comments you have here:

---



---



---



---